

1



Sintered bronze bearings

**oil-impregnated, ready for installation,
self-lubricating, maintenance-free.**

Oil-impregnated sintered bearings are maintenance-free, self-lubricating constructional elements of high reliability and performance. The material has microscopic pores which are filled with liquid (approx. 30 percent by volume oil) or solid (MOS 2) lubricant, depending on the requirements.

Main feature of sintered bearings:
High frictional speed at low load

The bearings – cylindrical as well as collar bearings – are available in many dimensions and are supplied ready for installation from stock.

Furthermore, we supply solid sintered and graphite bronze pieces up to a diameter and a length of 80 mm for further processing – special dimensions on request – as well as silencers made from sintered bronze.

Permissible loads and speeds

	Sintered bronzes	Sintered iron	Graphite bronze	Graphite bronze water lubricated
p.v (N/mm ² · m/s) continuous run Service life 10.000 h	1,6	1,6	0,4	0,3
p. max. (N/mm ²) Continuous run Peripheral speed approx. 0.17 m/s	10,0	9,5	2,5	2,5
p.max (N/mm ²) Static load 0.1% deformation	50,0	50,0	40,0	40,0
v.max (m/s) Continuous run	5,0	5,0	0,25	2,5

Coefficient of friction

The coefficient of friction depends on various factors:

- Surface quality of the material of the other component
- Sliding speed
- Temperature

Oil-impregnated bearings:
approx. 0.05 – 0.10

Bearings with solid lubrication:
approx. 0.15 - 0.25

Information on the installation of cylindrical and collar bearings

Important:

The installation must be carried out with the utmost care, as porous bearings are prone to deformation.

Pressing in should be carried out using a press-in mandrel, as this ensures keeping to very precise tolerances.

The example below applies to bearings with a tolerance of E 7/r7

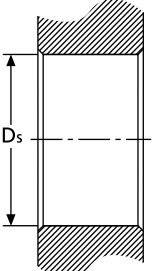
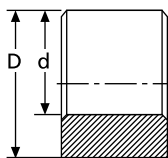
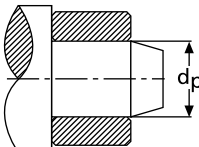
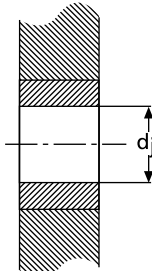
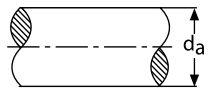
Locating hole Ds	Manufacturing tolerance of the bearing d/D	For installation of the bearings a press-in mandrel (d _p) is used		Shaft diameter d _a for running fit
		Before pressing in	After pressing in	
H 7	E 7/r 7	s 5	F7	h 8 h 9
				

Other tolerances for locating hole H 7 are available, e.g. F7/r7

Processing instructions for sintered materials

1

Generally, bearing bushes made from sintered material should not be subject to subsequent processing. However, if this is unavoidable, the following instructions should be observed. The slide faces of self-lubricating slide bearings must not be processed by any means involving friction or abrasion, as this may clog the pores

and self-lubrication will no longer be certain. However self-lubricating bearings can be returned.

For this purpose, diamond or hard metal tools quality 150 K20 or K01 with a maximum radius between 0.1 and 0.2 mm must be used.

Cutting conditions	Roughing work	Finishing work
Cutting speed (m/min)	160 – 210	150 – 200
Advance (mm/Umdr.)	bis 0,4	bis 0,2
Rate of cut (mm)	bis 2,0	0,2 – 0,4

Mechanical processing of sintered metal bearings must be performed without wet cooling. It is recommended that compressed air is used for cooling. It is strongly recommended that the part is thoroughly cleaned after mechanical processing and before impregnating with oil.

After mechanical processing, the loss of oil must be compensated for. For this purpose, place the bearing in a container filled with oil.

The oil – SAE 20 W with a viscosity of 3.5E degrees or similar – is heated up to a temperature of 80 degrees. Leave the parts in the oil bath until the oil has cooled down.

If subsequent processing is unavoidable (never process the surface of bearings made from sintered iron), this must be carried out by turning using diamond or hard metal tools, ISO quality K 20.

Tool radius 0,1 - 0,2 mm

V = 100 - 200 m/min

no friction

no grinding

Cutting angle on the cutting tool:

Clearance angle A = 6 – 8 degrees

Wedge angle B = 70 – 75 degrees

Rake angle C = 9 – 12 degrees

Instructions for keeping bearings in stock

Self-lubricating bearings contain about 30 percent by volume oil. If the bearings are stored inappropriately (e.g. on wood, in paper or cardboard boxes, oil may be lost. Please keep the be-

arings in the aluminium foil or in the plastic bags until they are installed. This protects the bearings against dust or other dirt, which is very important for proper functioning of the bearings.

Cylindrical bearings

Sintered bronze

oil-impregnated, self-lubricating, maintenance-free,
ready for installation

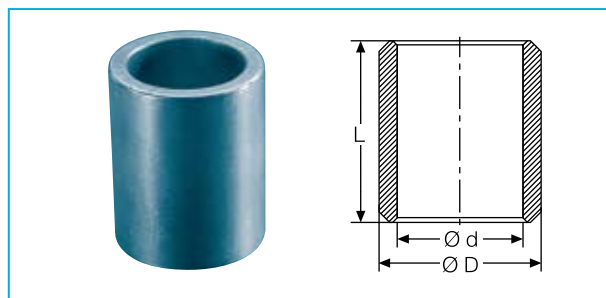

Dimensions d / D x L mm		
2/	4 x	4
3/	6 x	6
3/	6 x	10
3/	8 x	4
4/	6 x	5
4/	8 x	4
4/	8 x	6
4/	8 x	8
4/	8 x	10
4/	8 x	12
4/	10 x	8
5/	8 x	5
5/	9 x	10
5/	10 x	6
5/	10 x	8
5/	10 x	10
5/	12 x	10
6/	9 x	4
6/	9 x	6
6/	9 x	10
6/	9 x	12
6/	9 x	16
6/	10 x	4
6/	10 x	6
6/	10 x	10
6/	10 x	12
6/	10 x	16
6/	12 x	6
6/	12 x	8
6/	12 x	10
6/	12 x	12
6/	14 x	12
8/	11 x	6
8/	11 x	8
8/	11 x	12
8/	12 x	6
8/	12 x	8
8/	12 x	10

Dimensions d / D x L mm		
8/	12 x	12
8/	12 x	20
8/	14 x	8
8/	14 x	12
8/	14 x	16
8/	14 x	20
8/	18 x	16
10/	13 x	16
10/	14 x	8
10/	14 x	10
10/	14 x	16
10/	14 x	20
10/	14 x	25
10/	16 x	8
10/	16 x	10
10/	16 x	16
10/	16 x	20
10/	16 x	25
10/	18 x	20
10/	22 x	20
12/	15 x	12
12/	15 x	16
12/	15 x	20
12/	16 x	8
12/	16 x	12
12/	16 x	16
12/	16 x	20
12/	16 x	25
12/	18 x	12
12/	18 x	16
12/	18 x	20
12/	18 x	25
12/	25 x	25
14/	18 x	10
14/	18 x	14
14/	18 x	20
14/	18 x	22
14/	20 x	10

Dimensions d / D x L mm		
14/	20 x	12
14/	20 x	14
14/	20 x	20
14/	20 x	28
14/	20 x	30
14/	28 x	30
15/	19 x	10
15/	19 x	15
15/	19 x	16
15/	19 x	25
15/	20 x	15
15/	20 x	20
15/	20 x	25
15/	21 x	10
15/	21 x	15
15/	21 x	16
15/	21 x	20
15/	21 x	25
15/	22 x	16
15/	22 x	20
15/	22 x	30
15/	30 x	30
16/	20 x	12
16/	20 x	16
16/	20 x	25
16/	22 x	12
16/	22 x	16
16/	22 x	20
16/	22 x	25
16/	22 x	30
16/	32 x	30
18/	22 x	12
18/	22 x	18
18/	22 x	28
18/	22 x	30
18/	24 x	12
18/	24 x	18
18/	24 x	30

Dimensions d / D x L mm		
18/	25 x	16
18/	25 x	18
18/	25 x	20
18/	25 x	22
18/	25 x	28
18/	25 x	30
18/	25 x	36
18/	35 x	30
20/	25 x	15
20/	25 x	20
20/	25 x	25
20/	26 x	15
20/	26 x	16
20/	26 x	20
20/	26 x	25
20/	26 x	30
20/	26 x	32
20/	28 x	16
20/	28 x	20
20/	28 x	25
20/	28 x	30
20/	28 x	36
20/	28 x	40
20/	30 x	20
20/	40 x	40
22/	27 x	15
22/	27 x	20
22/	27 x	25
22/	32 x	20
22/	32 x	30
25/	30 x	20
25/	30 x	25
25/	30 x	30
25/	30 x	40
25/	32 x	20
25/	32 x	25
25/	32 x	30
25/	32 x	35

Cylindrical bearings

Sintered bronze

oil-impregnated, self-lubricating, maintenance-free,
ready for installation

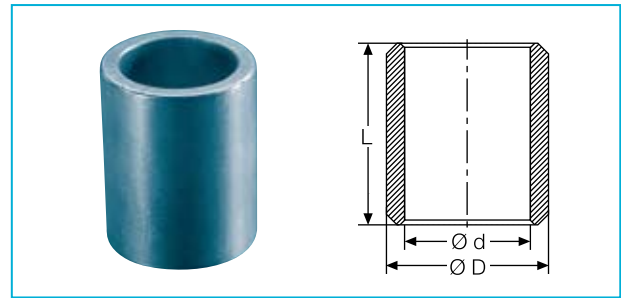

Dimensions d / D x L mm		
25/ 32 x 40		
25/ 35 x 25		
25/ 35 x 30		
25/ 35 x 45		
25/ 35 x 50		
25/ 45 x 35		
28/ 32 x 22		
28/ 32 x 28		
28/ 32 x 45		
28/ 33 x 22		
28/ 36 x 22		
28/ 36 x 25		
28/ 36 x 28		
30/ 35 x 20		
30/ 35 x 25		
30/ 35 x 30		
30/ 35 x 35		
30/ 38 x 20		
30/ 38 x 25		
30/ 38 x 30		
30/ 38 x 40		
30/ 40 x 25		
30/ 40 x 25		
30/ 40 x 30		
30/ 40 x 40		
30/ 40 x 45		
30/ 40 x 50		
30/ 40 x 60		
30/ 50 x 60		
32/ 38 x 20		
32/ 38 x 25		
32/ 38 x 32		
32/ 38 x 40		
32/ 40 x 30		
32/ 40 x 40		
32/ 40 x 50		
35/ 41 x 25		
35/ 41 x 35		

Dimensions d / D x L mm		
35/ 41 x 40		
35/ 44 x 22		
35/ 44 x 28		
35/ 44 x 35		
35/ 44 x 36		
35/ 45 x 25		
35/ 45 x 35		
35/ 45 x 40		
35/ 45 x 50		
35/ 45 x 70		
40/ 46 x 25		
40/ 46 x 30		
40/ 46 x 40		
40/ 46 x 50		
40/ 50 x 25		
40/ 50 x 30		
40/ 50 x 40		
40/ 50 x 50		
40/ 50 x 60		
40/ 50 x 80		
45/ 51 x 35		
45/ 51 x 45		
45/ 51 x 55		
45/ 55 x 35		
45/ 55 x 45		
45/ 55 x 55		
45/ 55 x 60		
45/ 55 x 65		
45/ 65 x 80		
50/ 60 x 35		
50/ 60 x 40		
50/ 60 x 50		
50/ 60 x 70		
50/ 60 x 100		
50/ 70 x 70		
55/ 65 x 40		
55/ 65 x 55		
55/ 65 x 70		

Dimensions d / D x L mm		
55/ 70 x 70		
60/ 68 x 50		
60/ 68 x 60		
60/ 68 x 70		
60/ 70 x 50		
60/ 70 x 60		
60/ 70 x 90		
60/ 70 x 120		
60/ 72 x 50		
60/ 72 x 60		
60/ 72 x 70		
60/ 75 x 60		
60/ 75 x 90		
60/ 85 x 90		
65/ 75 x 60		
65/ 75 x 90		
65/ 80 x 60		
65/ 80 x 90		
70/ 80 x 60		
70/ 80 x 90		
70/ 85 x 60		
70/ 85 x 90		
70/ 100 x 100		
75/ 85 x 70		
75/ 85 x 100		
75/ 90 x 70		
75/ 90 x 100		
80/ 90 x 70		
80/ 90 x 100		
80/ 95 x 70		
80/ 95 x 100		
80/ 100 x 120		
80/ 105 x 100		
85/ 95 x 100		
85/ 100 x 100		
90/ 105 x 80		
90/ 110 x 80		
100/ 120 x 80		

Dimensions d / D x L mm		
100/ 120 x 100		
100/ 120 x 120		

Collar bearings

Sintered bronze

oil-impregnated, self-lubricating, maintenance-free,
ready for installation

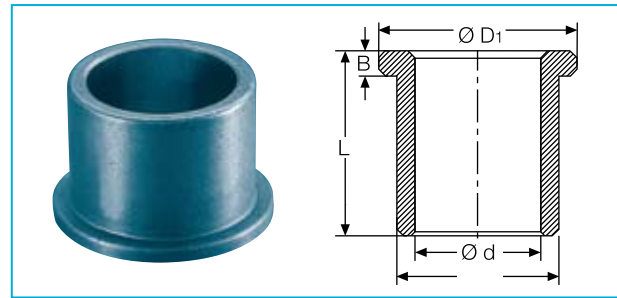

Dimensions			
d / D / D1	x	L / B	mm
3/ 5/	8 x	4/1,5	
3/ 6/	9 x	4/1,5	
4/ 8/	12 x	4/2	
4/ 8/	10 x	6/2	
4/ 8/	12 x	6/2	
5/ 9/	13 x	4/2	
5/ 9/	13 x	5/2	
5/ 9/	13 x	8/2	
5/ 10/	12 x	6/2	
6/ 10/	14 x	4/2	
6/ 10/	14 x	6/2	
6/ 10/	14 x	10/2	
6/ 10/	14 x	16/2	
6/ 12/	14 x	6/2	
8/ 12/	16 x	6/2	
8/ 12/	16 x	8/2	
8/ 12/	16 x	12/2	
8/ 14/	18 x	8/3	
10/ 13/	16 x	10/1,5	
10/ 13/	16 x	20/1,5	
10/ 15/	20 x	10/2,5	
10/ 15/	20 x	15/3	
10/ 15/	20 x	20/2,5	
10/ 16/	22 x	8/3	
10/ 16/	22 x	10/3	
10/ 16/	22 x	16/3	
10/ 16/	20 x	20/3	
12/ 16/	18 x	20/2	
12/ 18/	24 x	8/3	
12/ 18/	22 x	12/3	
12/ 18/	24 x	12/3	
12/ 18/	24 x	20/3	
14/ 20/	26 x	10/3	

Dimensions			
d / D / D1	x	L / B	mm
14/ 20/	26 x	14/3	
14/ 20/	26 x	20/3	
15/ 21/	27 x	10/3	
15/ 21/	27 x	15/3	
15/ 21/	27 x	25/3	
15/ 22/	28 x	12/3	
15/ 22/	28 x	16/3	
16/ 20/	24 x	16/2	
16/ 20/	24 x	20/2	
16/ 22/	28 x	12/3	
16/ 22/	28 x	16/3	
16/ 22/	28 x	20/3	
16/ 22/	28 x	25/3	
16/ 22/	28 x	32/3	
18/ 24/	30 x	12/3	
18/ 24/	30 x	18/3	
18/ 24/	30 x	30/3	
18/ 25/	32 x	12/4	
18/ 25/	32 x	16/4	
20/ 26/	32 x	15/3	
20/ 26/	32 x	20/3	
20/ 26/	32 x	25/3	
20/ 26/	32 x	30/3	
20/ 28/	35 x	16/4	
20/ 28/	35 x	20/4	
22/ 29/	36 x	18/3,5	
22/ 29/	36 x	22/3,5	
25/ 32/	39 x	20/3,5	
25/ 32/	39 x	25/3,5	
25/ 32/	39 x	30/3,5	
25/ 35/	45 x	16/5	
25/ 35/	45 x	25/5	
30/ 38/	46 x	20/4	

Dimensions			
d / D / D1	x	L / B	mm
30/ 38/	46 x	25/4	
30/ 38/	46 x	30/4	
30/ 40/	50 x	20/5	
30/ 40/	50 x	30/5	
32/ 40/	48 x	20/4	
32/ 40/	48 x	30/4	
35/ 45/	55 x	20/5	
35/ 45/	55 x	25/5	
35/ 45/	55 x	35/5	
35/ 45/	55 x	40/5	
40/ 50/	60 x	25/5	
40/ 50/	60 x	30/5	
40/ 50/	60 x	40/5	
40/ 50/	60 x	50/5	
45/ 55/	65 x	35/5	
45/ 55/	65 x	45/5	
45/ 55/	65 x	55/5	
50/ 60/	70 x	35/5	
50/ 60/	70 x	40/5	
50/ 60/	70 x	50/5	
60/ 72/	84 x	50/6	
60/ 72/	84 x	60/6	
60/ 75/	85 x	35/8	
60/ 75/	85 x	60/8	
70/ 85/	95 x	60/8	
80/ 95/	105 x	70/8	
90/ 110/	120 x	50/8	
100/ 120/	130 x	80/8	

Solid pieces made from sintered bronze and graphite bronze

After processing, the pieces must be impregnated with oil
(this only applies to sintered bronze, not to graphite bronze).

1

Sintered bronze Dimensions D x L mm

20 x 52
30 x 52
40 x 52
50 x 60
60 x 60
80 x 80

Graphite bronze Dimensions D x L mm

10 x 22
20 x 52
30 x 52
40 x 52
50 x 60
60 x 60
80 x 80

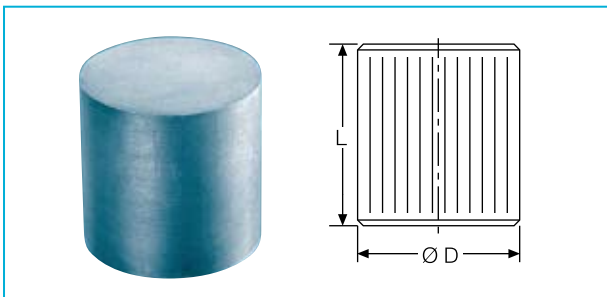

Silencers

Silencers are supplied together with an O-ring in order to ensure that they do not become detached as a result of vibration.

Dimensions Ø x L mm

R 1/8 Zoll x 20
R 1/4 Zoll x 27
R 3/8 Zoll x 36
R 1/2 Zoll x 44
R 3/4 Zoll x 63
R 1 Zoll x 77

